

XP-8 OPEN-STACKING Quick Ship Loading Spout
- General Specifications -

The XP-8 OPEN-STACKING Quick Ship Bulk Loading Spout is designed to provide Dust-Free loading (200 CFM Maximum Loading Capacity) of dry bulk materials into open trucks, railcars or open stockpiles. The dust generated during loading is withdrawn from the point of discharge and through the annular passage between the product guide cones and the ROADSTAR 18® shroud. Once inside this passage, the velocity of the air stream decreases. This allows the relatively dense particulate to be drawn back into the gravity fed product stream. Extremely fine particulate continues through the negative air connection and into the user's ventilation system. For adequate ventilation, we recommend 800-1000 CFM of negative air.

- Standard Features -

- 1.1 Non-contact components of 12 gauge carbon steel.
- 1.2 Up to 14 feet of Vertical Travel.
- 1.3 Flat-Faced product inlet ~ 16" diameter with blind flange for field adaptation.
- 1.4 75 degree sloped product inlet chute transition.
- 1.5 8" diameter flat-faced negative air connection.
- 1.6 5/16" thick Polyethylene internal self-stacking product guide cones.
- 1.7 Flexible "ROADSTAR 18" shroud with internal galvanized steel reinforcing rings.
- 1.8 Double sprocket and chain drive. (not shown)
- 1.9 Full-Up and Full-Down rotary limit switch & Slack cable swithes. (not shown)
- 1.10 Level Sensor to Control Retracted Height factory wired to J.I.C. junction box.
- 1.11 Anti-Plugging Level Sensor factory wired to J.I.C. junction box.
- 1.12 Three cable hoist and drive enclosed with guard and dust cover.
- 1.13 Loading spout is factory assembled, wired, inspected and tested then skidded and crated for ease of shipment and installation.
- 1.14 Unit to be supported from Support Mounting Angles (by others).
- 1.15 Heavy duty gearmotor (50:1) with 1/2 HP ~ 1800 RPM ~ TEFC motor with intergal brake for cable hoist drive ~ 3ph/60Hz operation with

230 VAC 460 VAC

- Optional Features -

- 2.1 Product Inlet Flanges
 8" 10" 12" 14" Diameter
A.N.S.I. drilled raised-face flange.
- 2.2 Electrical Control Pendant
 Operator's control pendant in a NEMA 4x enclosure wired to J.I.C. Junction Box.
- 2.3 Metal Inner Chute
 3/16" thick Abrasion Resistant Steel
- 2.4 Metal Inner Cones
 3/16" thick Abrasion Resistant Steel
- 2.5 R.F. Negative Air Connection Flange
 Carbon Steel (SEE DWG. R.F. FLANGE)
- 2.6 No Optional Features Selected

"AA" Vertical Travel	"BB" Retracted Height	"CC" Extended Length
2'-0"	2'-1"	4'-0"
3'-0"	2'-3"	5'-3"
4'-0"	2'-6"	6'-6"
5'-0"	2'-9"	7'-9"
6'-0"	3'-0"	9'-0"
7'-0"	3'-3"	10'-3"
8'-0"	3'-6"	11'-6"
9'-0"	3'-9"	12'-9"
10'-0"	4'-0"	14'-0"
11'-0"	4'-3"	15'-3"
12'-0"	4'-5"	16'-5"
13'-0"	4'-8"	17'-8"
14'-0"	4'-10"	18'-10"

Add 18" to Retracted Height for Dust Skirt

APPLICATION: _____
 PRODUCT: _____
 LOADING RATE: ___ TONS/Hr.
 BULK DENSITY: ___ LBS./CF
 ELECTRICAL SCHEMATIC: C-800____
 CUSTOMER P.O. No. _____

REF	QUANT	REF.	DESCRIPTION
DRAWN BY	?		
DATE	?		
CHECKED BY			
SCALE			
ORDER	?	JOB	?
DO NOT SCALE DWG.			

SLY INC. SLY Incorporated
 LOADING SPOUT & POSITIONER PRODUCTS
 P.O. BOX 5939, CLEVELAND, OHIO 44101
 (440)891-3200 * FAX:(440)891-3210

XP-8 O.S. QUICK SHIP LOADING SPOUT

XP-8 OS

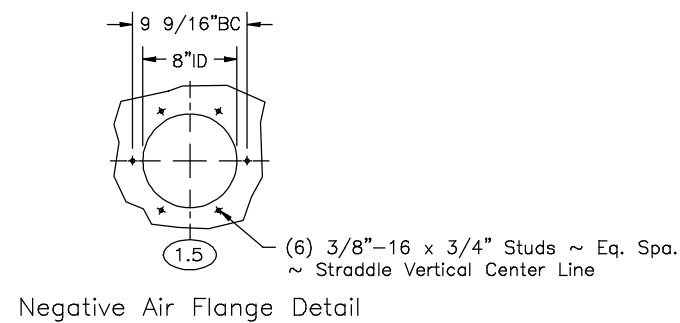
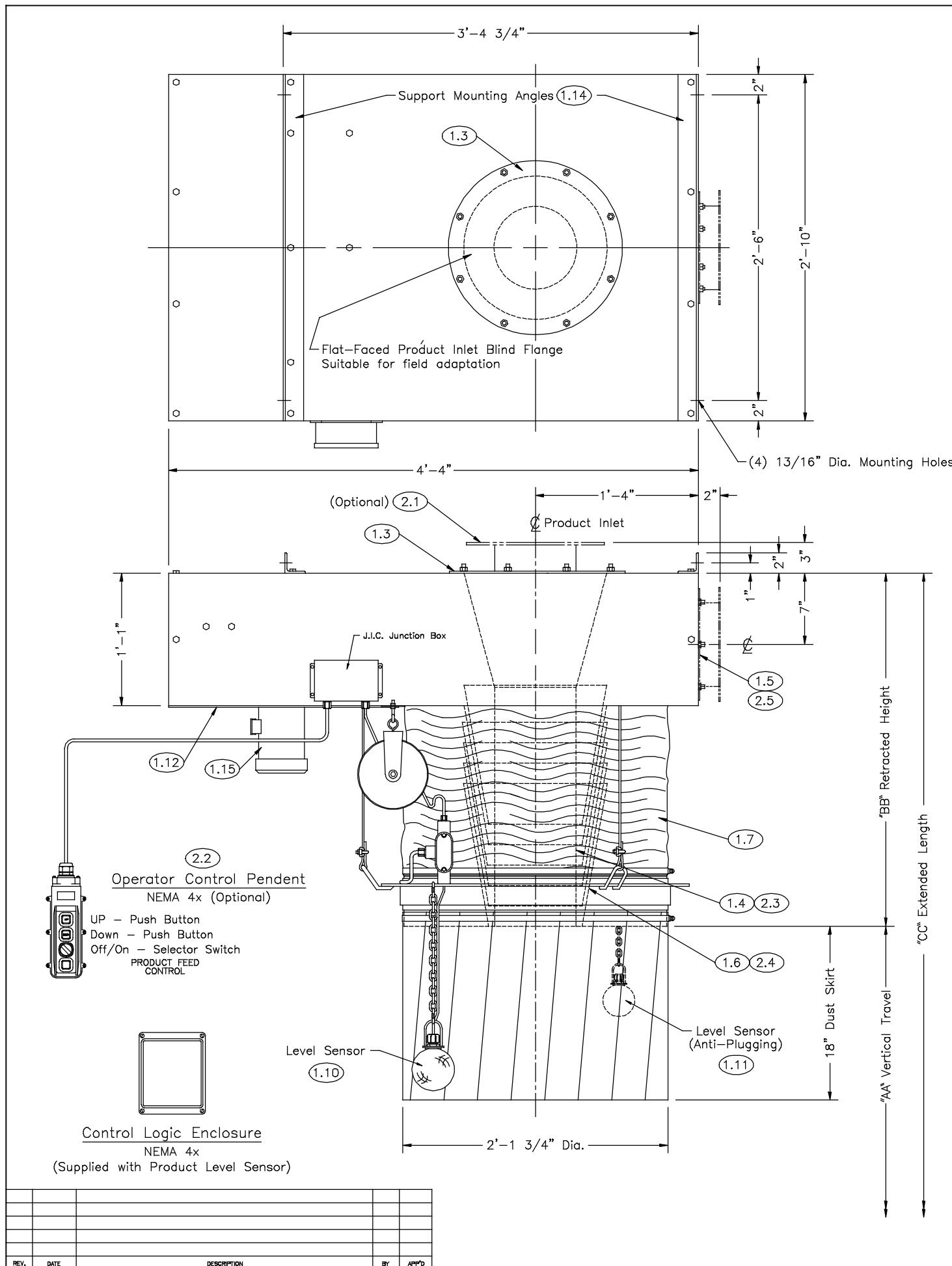

Product Inlet Raised Face Flange
(OPTIONAL)
A.N.S.I. Standard Drilling
SEE DWG. R.F. FLANGE

REV.	DATE	DESCRIPTION	BY	APP'D