

Sly TubeJet Model STJ (TOP BAG REMOVAL)

Model No.	Bag Length (ft)	Cloth Area (SQ. ft.)	Bag Quantity	Air Usage (SCFM @ 90 psig)*	A	B	C	D	E	F
STJ-36-	6 8 10	163 217 271	18	11	2'-0"	4'-0"	2'-11"	8'-0"	1'-9 1/2"	3'-9 1/2"
STJ-46-	6 8 10	217 289 361	24	11	2'-8"	4'-0"	2'-11"	8'-0"	2'-5 1/2"	3'-9 1/2"
STJ-66-	6 8 10	325 434 542	36	11	4'-0"	4'-0"	2'-11"	8'-0"	3'-9 1/2"	3'-9 1/2"
STJ-68-	6 8 10	434 578 723	48	11	4'-0"	5'-4"	4'-1"	8'-7"	3'-9 1/2"	5'-1 1/2"
STJ-78-	6 8 10	506 674 843	56	11	4'-8"	5'-4"	4'-1"	8'-7"	4'-5 1/2"	5'-1 1/2"
STJ-88-	6 8 10	578 771 963	64	11	5'-4"	5'-4"	4'-1"	8'-7"	5'-1 1/2"	5'-1 1/2"
STJ-108-	6 8 10	723 963 1204	80	11	6'-8"	5'-4"	5'-3"	9'-9"	6'-5 1/2"	5'-1 1/2"

How to Determine Your Model Number

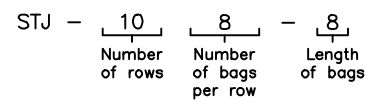

* Guideline based on 10 second off time between pulses and 100 millisecond pulse duration ~ may change based on application

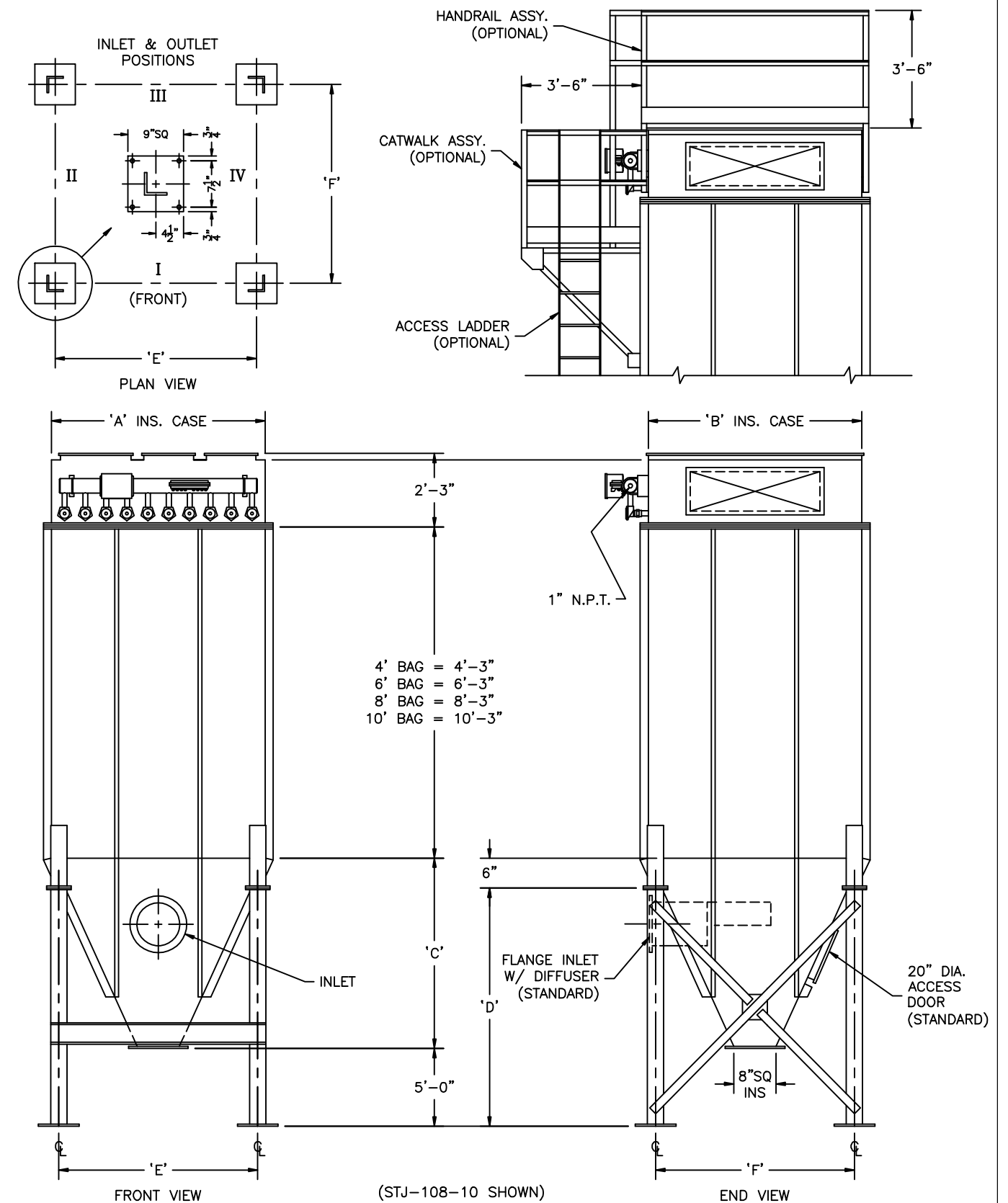

NOT FOR CONSTRUCTION

MODEL NO. _____
 VOLUME _____ CFM
 TEMPERATURE _____ °F
 DUST _____
 LOADING _____ GR/CF
 CLOTH AREA _____ SQ.FT.
 NO. OF BAGS _____
 A/C RATIO _____ :1
 PROCESS _____

- NOTES:
- Inlet size based on 3000 fpm maximum velocity.
 - Standard exhaust connection either right or left of header.
 - Standard trough hopper has same depth as pyramidal hopper.
 - Magnehelic gauge w/ bracket, tubing & fittings.
 - Unless otherwise specified, timers shipped assembled & pre-wired to solenoid enclosure.
 - Drawing dimensions are subject to change without prior notice.

SLY INC.
 TECHNOLOGY FOR A CLEAN ENVIROMENT
 8300 Dow Circle, Suite 600
 Strongsville, OH 44136
 1-800-334-2957
 In Ohio (440) 891-3200
 FAX: (440) 891-3210

STJ-501-1 (D)